

スリーポイントタイプ金型  
THREE POINT TYPE PRESS BRAKE TOOLS

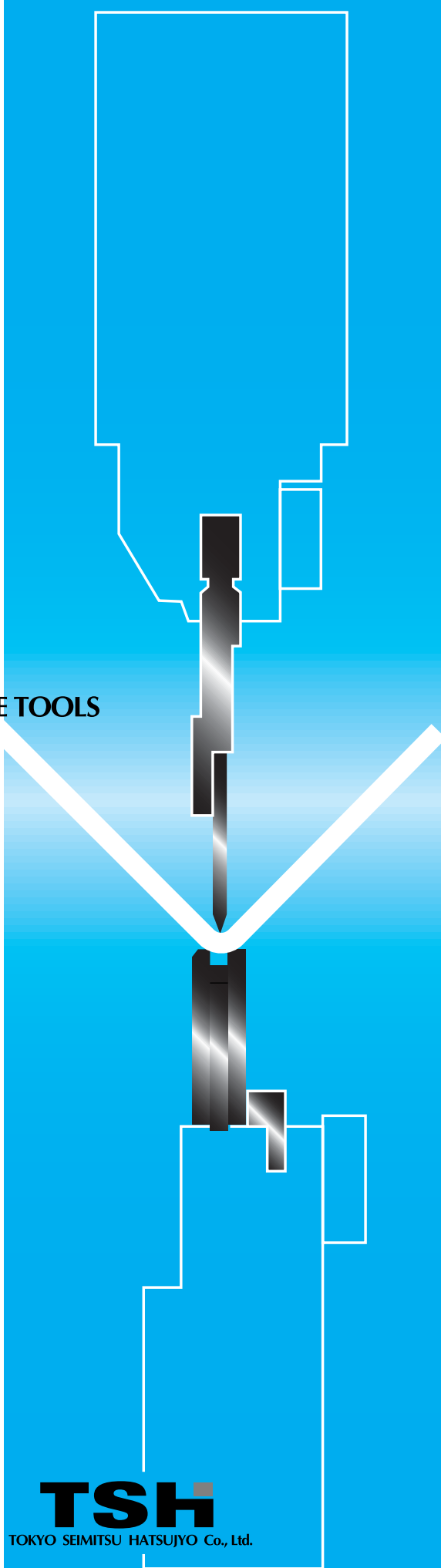

STANDARD TOOLS

**TSH**  
TOKYO SEIMITSU HATSUJYO Co., Ltd.

# Standard tools

TOKYO SEIMITSU HATSUJYO Co., Ltd.

## 標準金型

### 分割金型 (パンチ) Universally split top tool

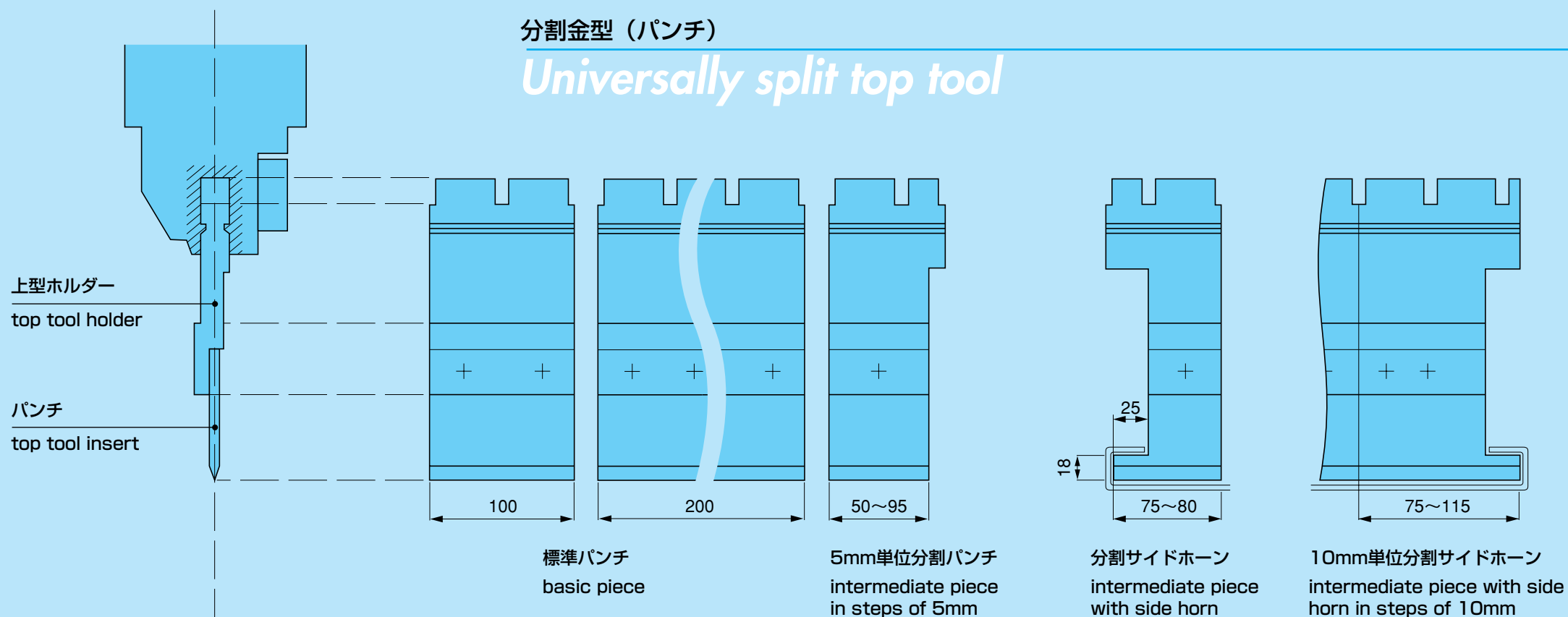

### ヘミング金型 Hemming

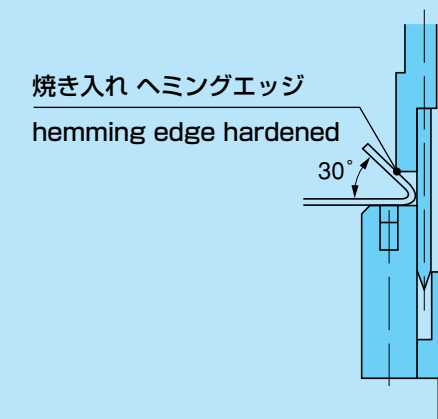

### ボルト付きダイ Universally split bottom tool incl. bolts

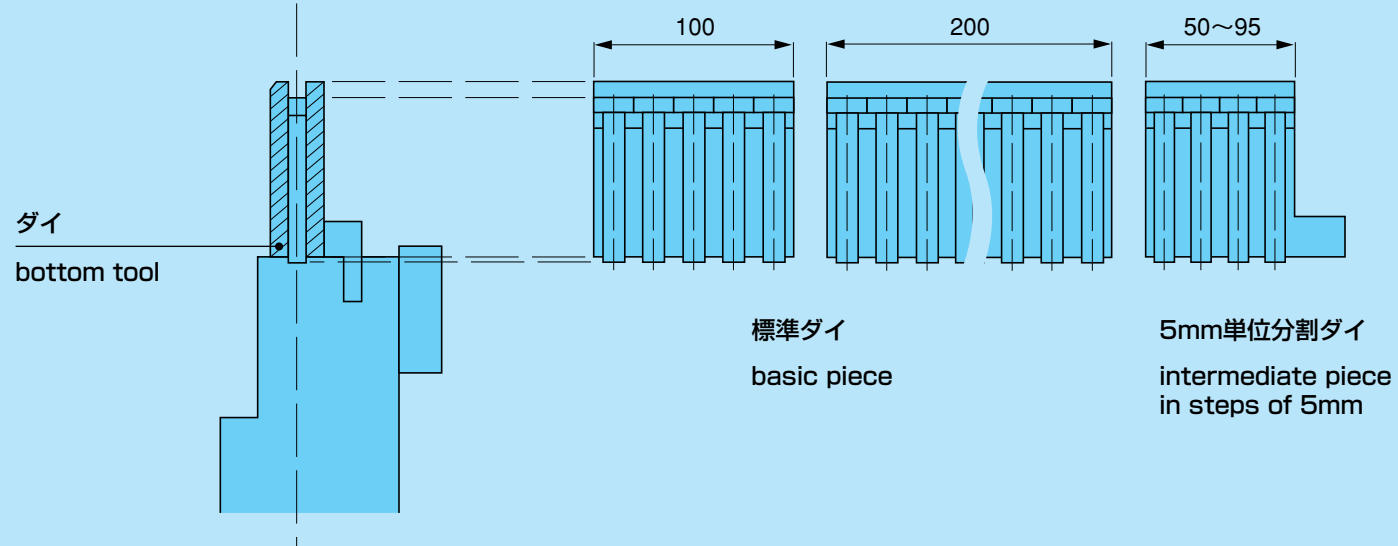

### 組み合わせ Combinations

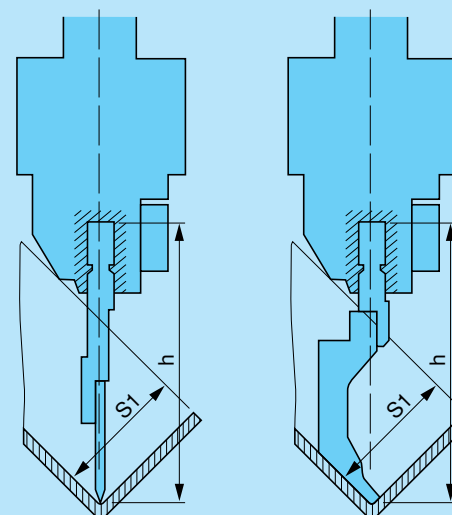

用例 examples	上型ホルダー Top tool holder	
245	110	TS11-001-00 / TS21-002-00 TS11-006-00 / TS21-002-00 TS12-015-00 / TS21-004-00
295	145	TS11-003-00 / TS21-002-00 (*2) TS12-065-00 / TS21-002-00
350	184	TS11-001-00 / TS21-005-00
400	219	TS12-015-00 / TS21-005-00

\*1 サイドフランジ最大高さ max.height of side flange

\*2 ヘミング不可 hemming not possible

(注) 特殊金型も製作致します。 We manufacture and supply special tools.

# Bottom tools

ダイ

TOKYO SEIMITSU HATSUJYO Co., Ltd.

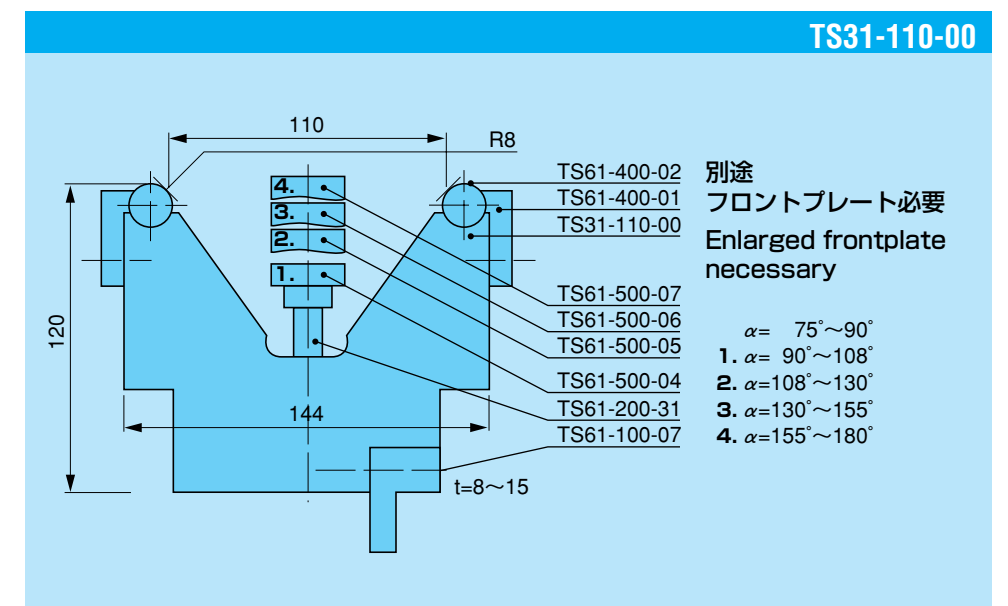
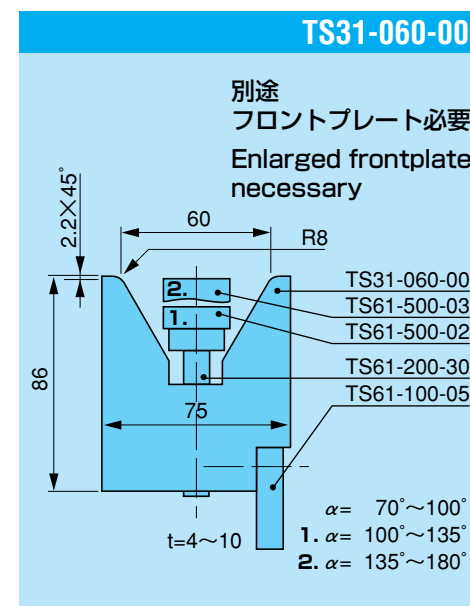
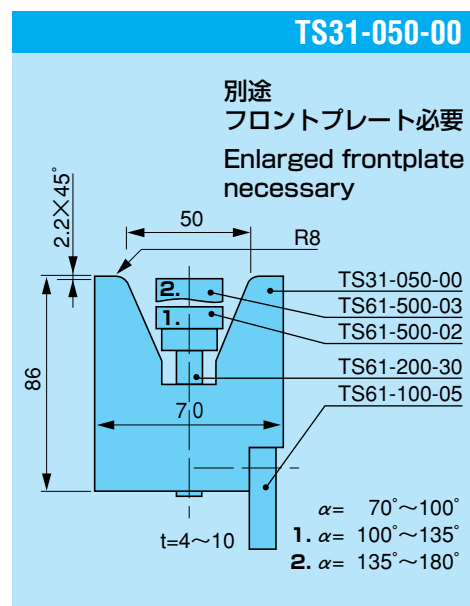
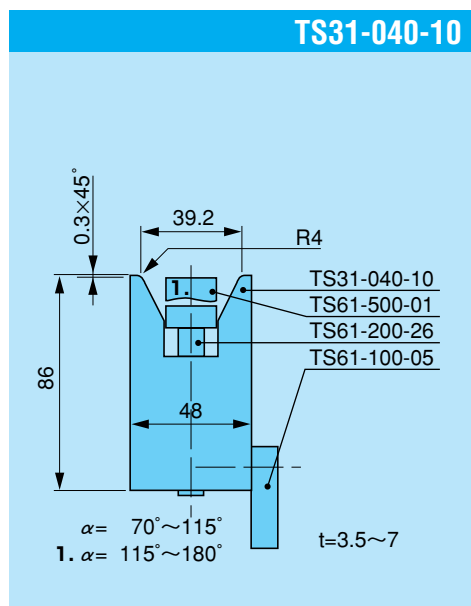
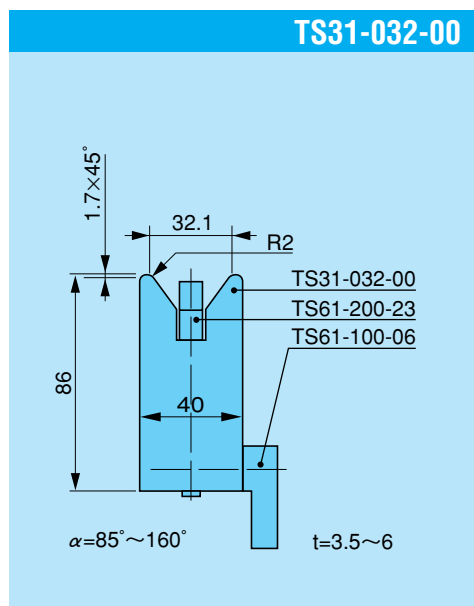
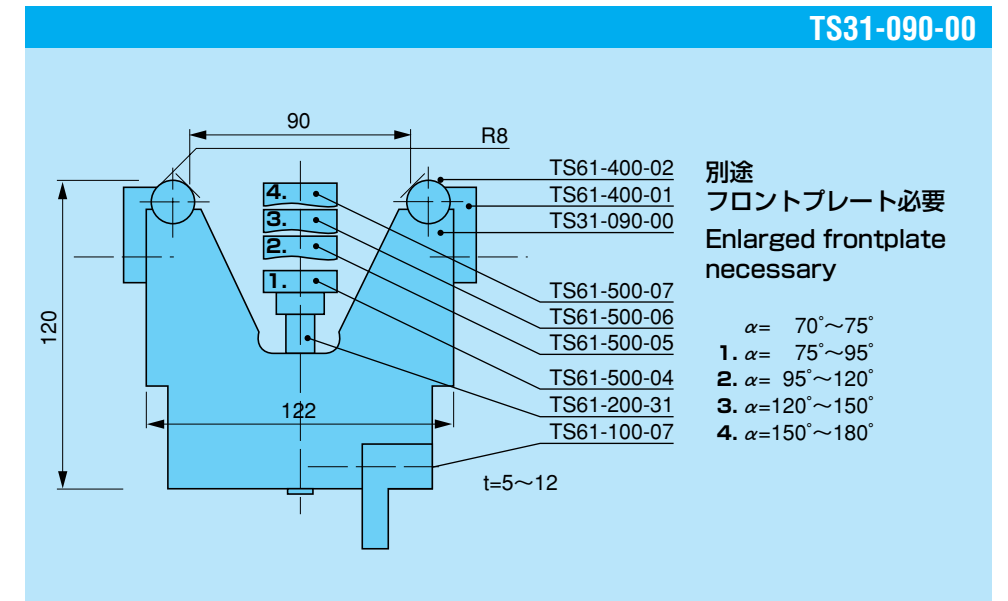
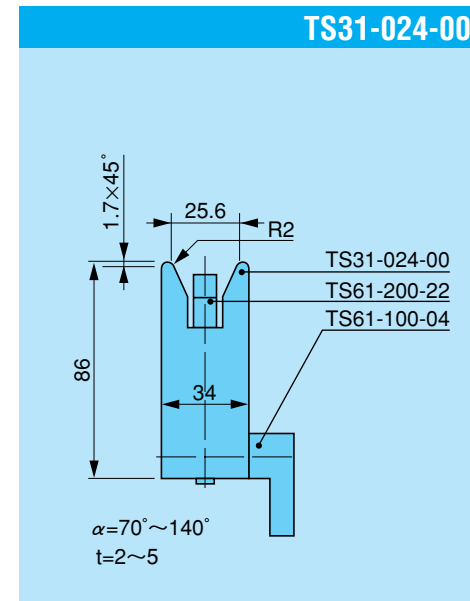
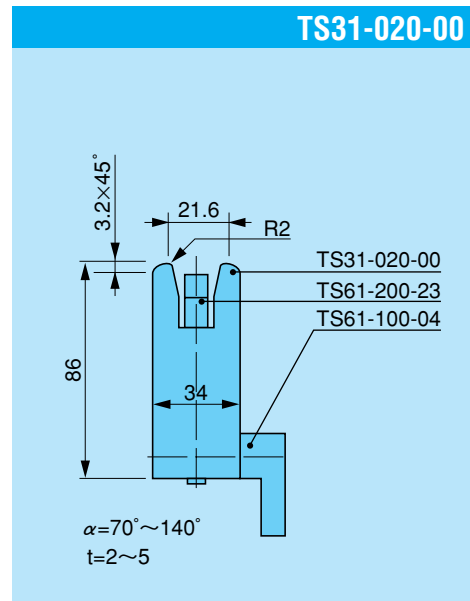
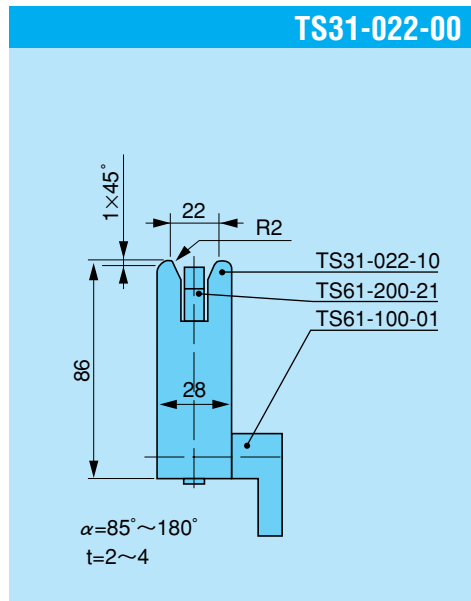
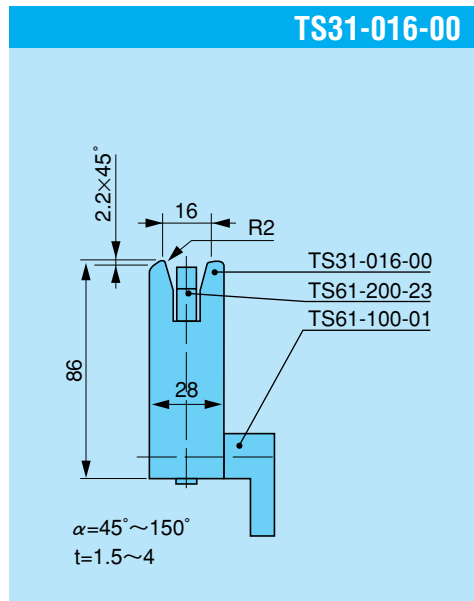
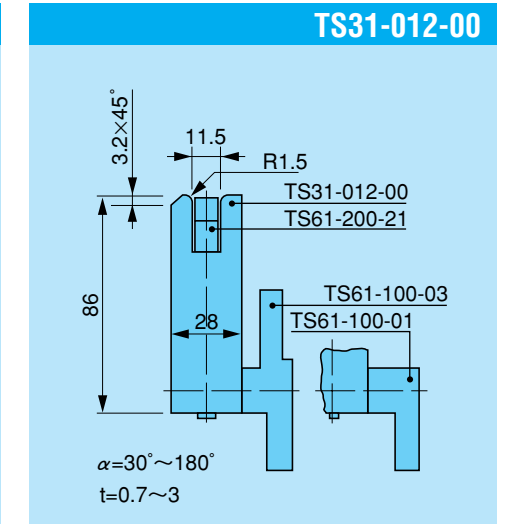
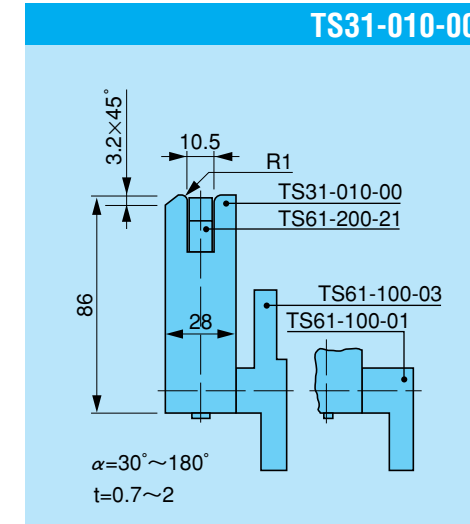
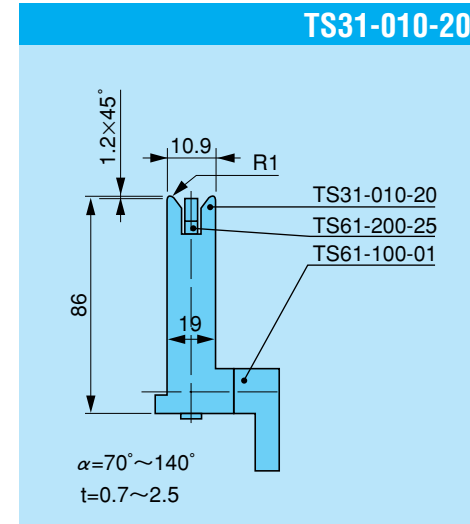
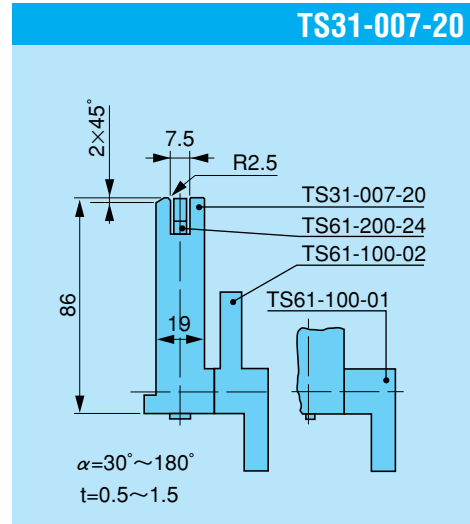
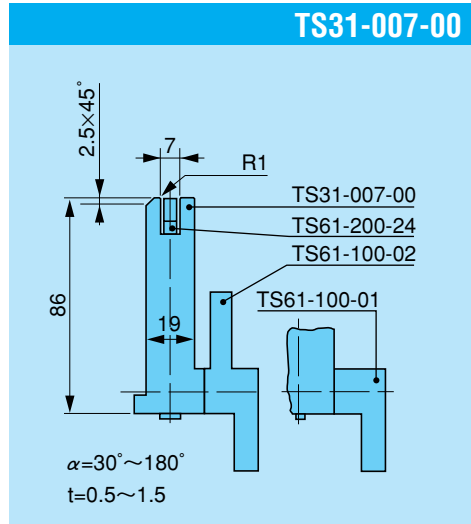
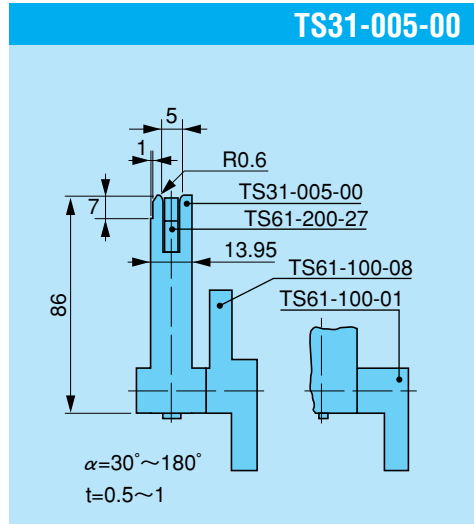

(注) ダイハイト120mmも製作しています。 We manufacture and supply dies whose height is 120mm.

# Top tools

## パンチ

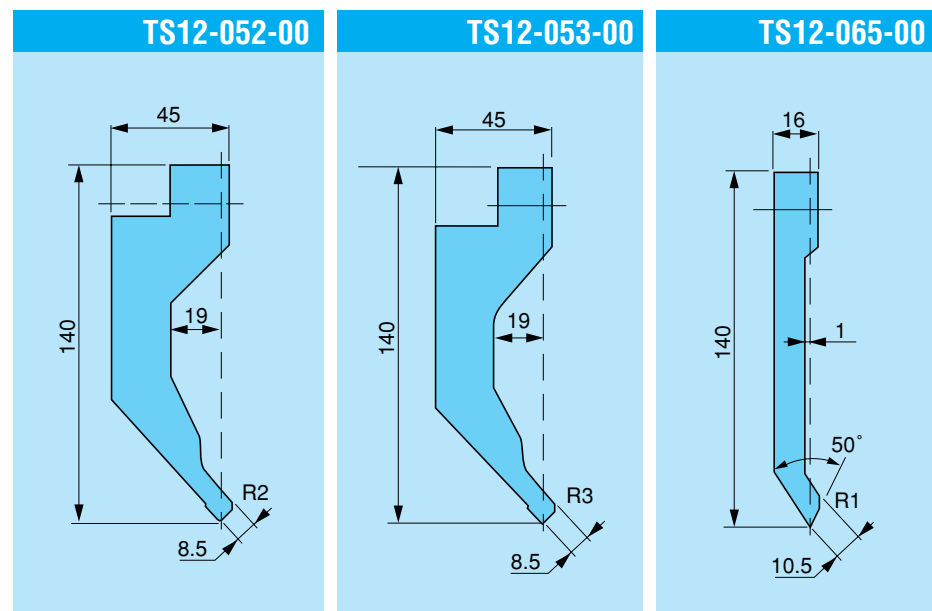
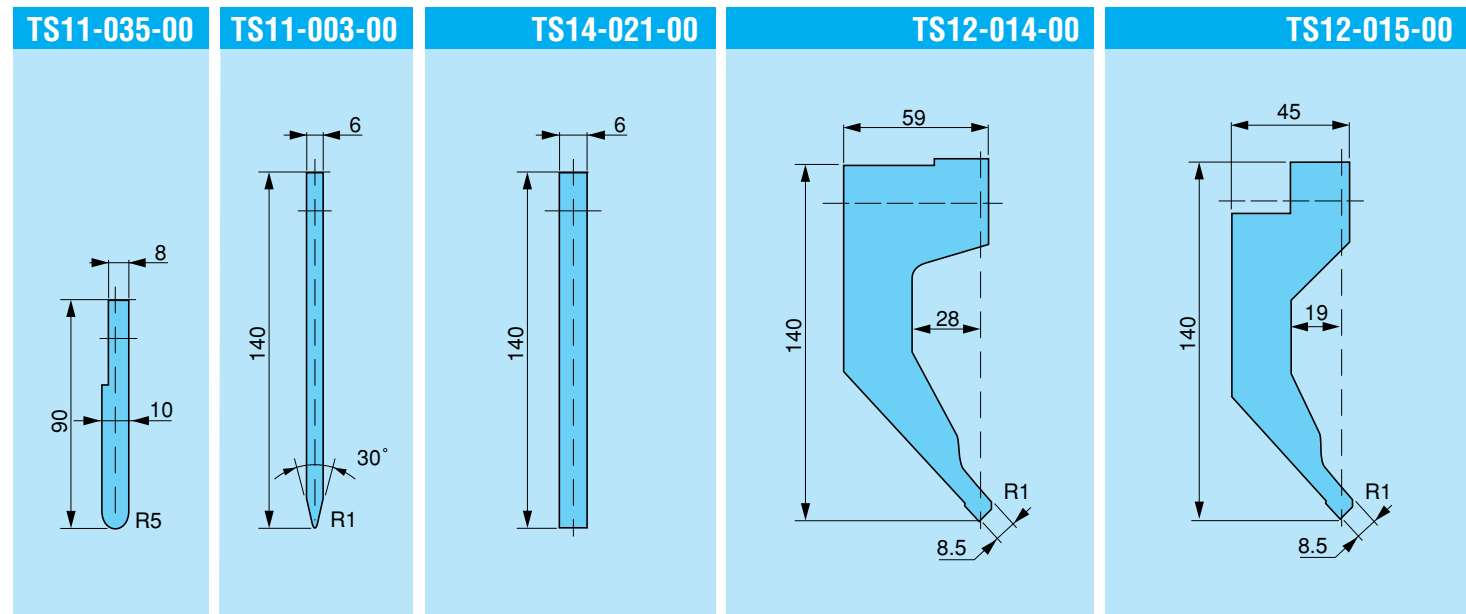
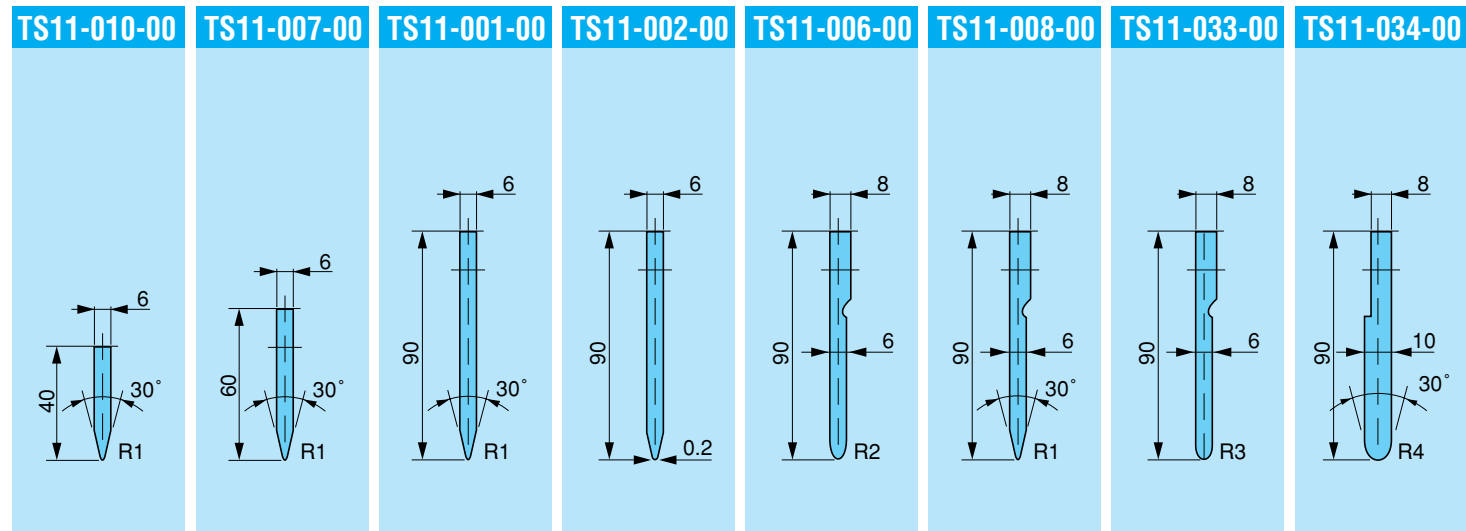

# Top tool holders

## 上型ホルダー

TOKYO SEIMITSU HATSUJYO Co., Ltd.

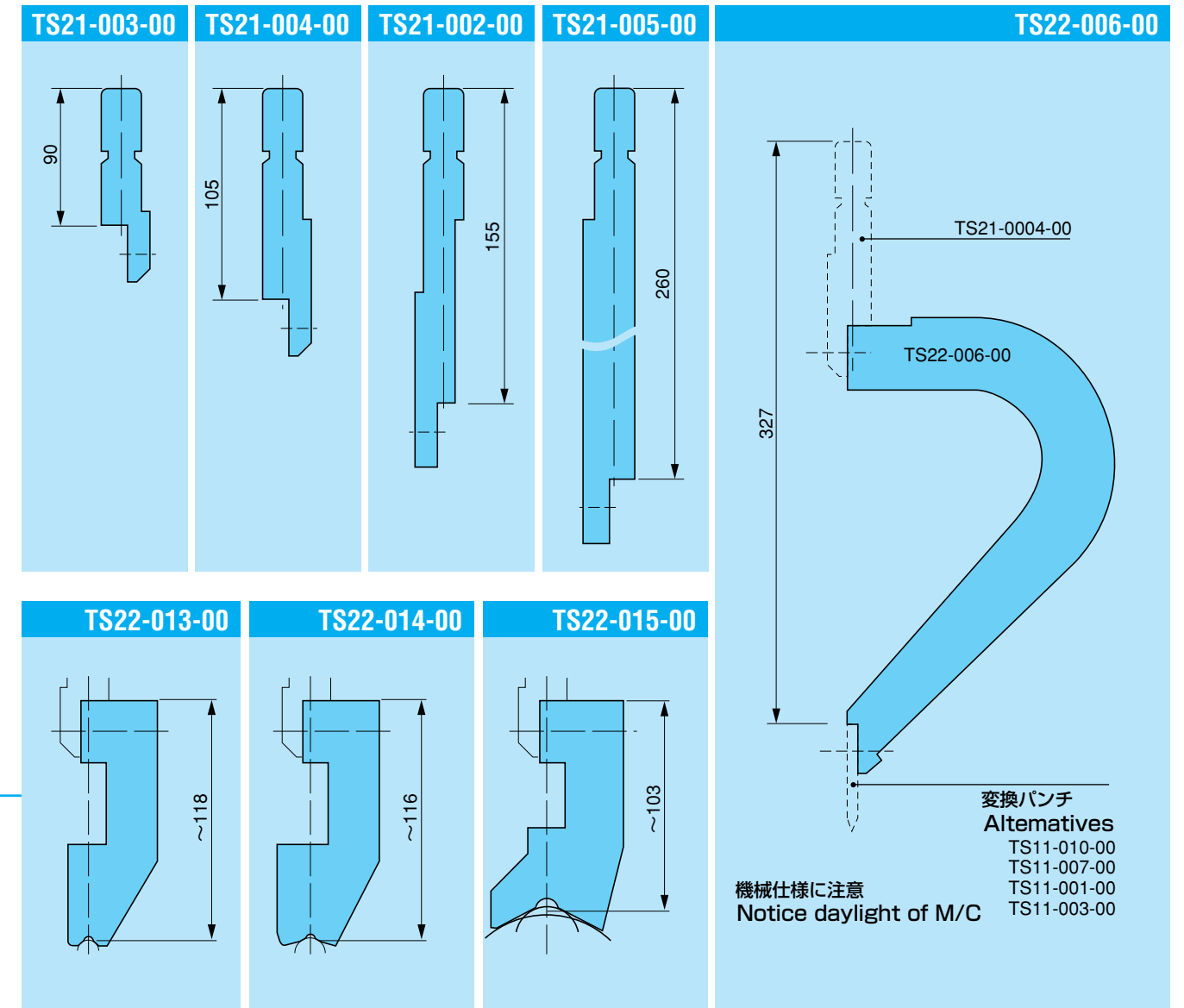

変換パンチ  
Alternatives  
TS11-010-00  
TS11-007-00  
TS11-001-00  
TS11-003-00  
機械仕様に注意  
Notice daylight of M/C

## ラジアスパンチ Radius Top Tool (Rod)

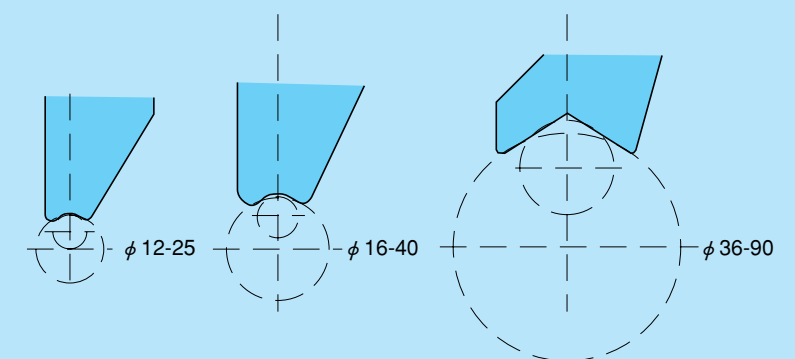

# Planishing bottom and top tools

TOKYO SEIMITSU HATSUJYO Co., Ltd.

## コイニング金型

TS41-005-00

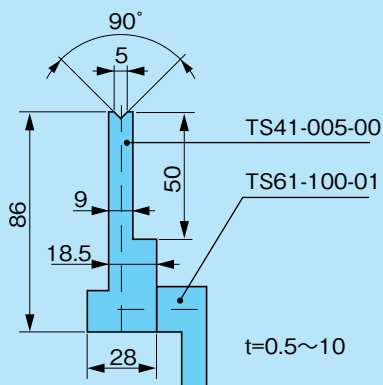

TS41-007-00

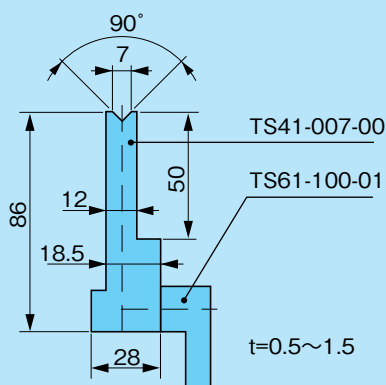

TS40-010-00

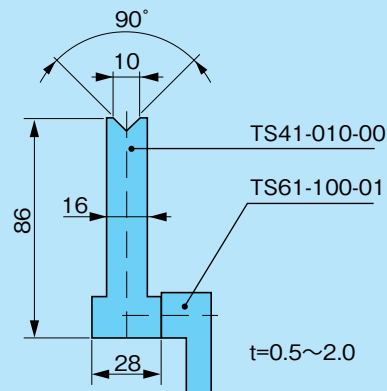

TS41-012-00

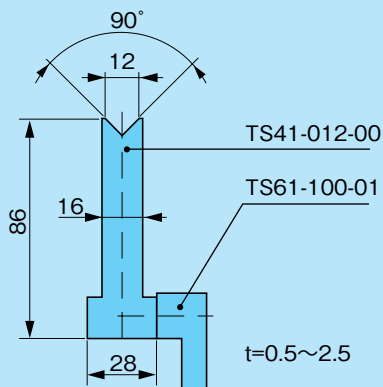

TS11-005-00

TS41-005-00 専用  
For TS41-005-00 only

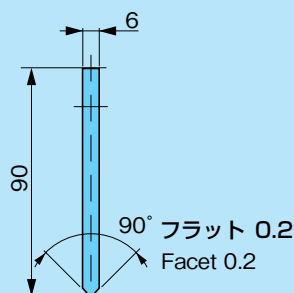

TS11-009-10

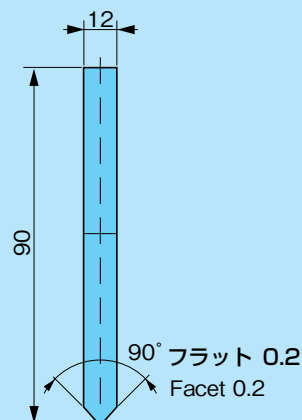

TS12-019-00

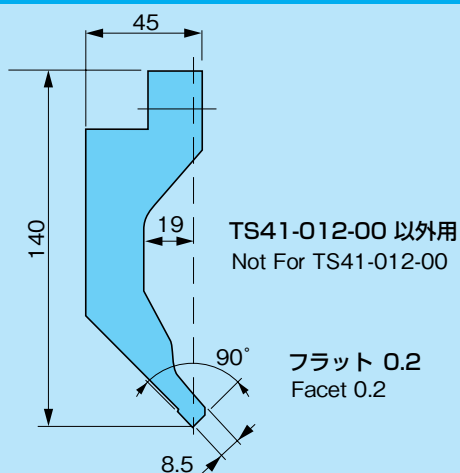

●改良のため予告なく製品の外観、仕様を変更することがあります。  
\*T.S.H. reserves the right to discontinue or change at any time specifications, or price without prior notice or obligation

## 東京精密発條株式会社

〒224-0045 神奈川県横浜市都筑区東方町134番地 TEL:045-624-9841 (代) FAX:045-624-9840  
URL: <http://www.to-hatsu.co.jp/>  
134 Higashikata-cho, Tsuzuki-ku, Yokohama-city, Kanagawa, 224-0045, Japan